

Lieriösokka kierteellä

DIN EN ISO 8735, Tyyppi A, mukaan. Aiemmin DIN 7979

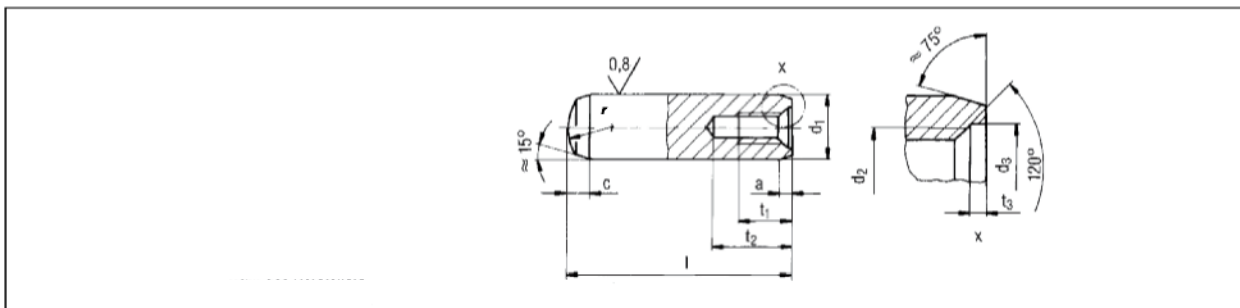

Koodi: 7227 .

Raaka-aine: Valmistajan erikoisteräs

Kovuus: 60 ± 2 HRC

d ₁ m6	4	5	6	8	10	12	13	14	16	20
r	4	5	6	8	10	12	13	14	16	20
d ₂	M 3	M 3	M 4	M 5	M 6	M 6	M 6	M 8	M 8	M 10
d ₃	3,3	3,3	4,3	5,3	6,4	6,4	6,4	8,4	8,4	10,5
t ₁	4,5-6	4,5-6	6	8	10	10	12	12	12	16
t ₂ min.	7-10	7-10	10	12	16	16	18	20	20	25
t ₃	0,8	0,8	1	1,2	1,2	1,2	1,2	1,2	1,5	1,5
a	0,4	0,5	0,8	1,0	1,2	1,6	1,8	1,8	2,0	2,5
C	1,3	1,7	2,1	2,6	3,0	3,8	3,8	4,0	4,6	6,0
Pituus l ₁										
8		●								
10	●	●								
12	●	●	●							
14	●	●	●							
16	●	●	●	●						
18	●	●	●	●						
20	●	●	●	●	●	●				
24	●	●	●	●	●	●				
28	●	●	●	●	●	●		●	●	
32	●	●	●	●	●	●	●	●	●	●
36	●	●	●	●	●	●		●	●	●
40	●	●	●	●	●	●	●	●	●	●
45		●	●	●	●	●		●	●	●
50	●	●	●	●	●	●	●	●	●	●
55		●	●	●	●	●		●	●	●
60		●	●	●	●	●	●	●	●	●
70		●	●	●	●	●	●	●	●	●
80			●	●	●	●	●	●	●	●
90			●	●	●	●		●	●	●
100			●	●	●	●	●	●	●	●
120				●	●	●	●	●	●	●