

PORAN TERÄT

ja

KIERRETERÄT



DAK-tyypin kovametalliterä

2-leikkuinen erikoispinnoitettu terä
30 ° kulmalla.

Kärkikulma 140 °

Raekoko 0,4 µm.

Soveltuu teräksille kovuuteen 52
HRC asti

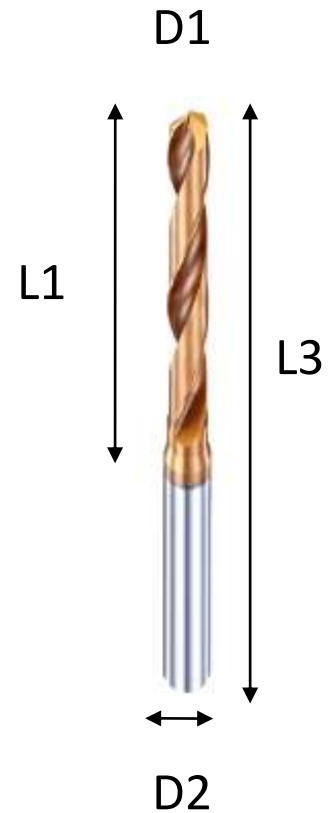

Tyyppi	Halkaisija/ D1	Leikkuu- pituus/L1	Kok.pituus/ L3	Kara/ D2
DAK030	3,0	20	62	6
DAK031	3,1	20	62	6
DAK032	3,2	20	62	6
DAK033	3,3	20	62	6
DAK034	3,4	20	62	6
DAK035	3,5	20	62	6
DAK036	3,6	20	62	6
DAK037	3,7	20	62	6
DAK038	3,8	24	66	6
DAK039	3,9	24	66	6
DAK040	4,0	24	66	6
DAK041	4,1	24	66	6
DAK042	4,2	24	66	6
DAK043	4,3	24	66	6
DAK044	4,4	24	66	6
DAK045	4,5	24	66	6
DAK046	4,6	24	66	6
DAK047	4,7	24	66	6
DAK048	4,8	28	66	6
DAK049	4,9	28	66	6
DAK050	5,0	28	66	6
DAK051	5,1	28	66	6
DAK052	5,2	28	66	6
DAK053	5,3	28	66	6
DAK054	5,4	28	66	6

Tyyppi	Halkaisija/ D1	Leikkuu- pituus/L1	Kok.pituus/ L3	Kara/ D2
DAK055	5,5	28	66	6
DAK056	5,6	28	66	6
DAK057	5,7	28	66	6
DAK058	5,8	28	66	6
DAK059	5,9	28	66	6
DAK060	6,0	28	66	6
DAK061	6,1	34	79	8
DAK062	6,2	34	79	8
DAK063	6,3	34	79	8
DAK064	6,4	34	79	8
DAK065	6,5	34	79	8
DAK066	6,6	34	79	8
DAK067	6,7	34	79	8
DAK068	6,8	34	79	8
DAK069	6,9	34	79	8
DAK070	7,0	34	79	8
DAK071	7,1	41	79	8
DAK072	7,2	41	79	8
DAK073	7,3	41	79	8
DAK074	7,4	41	79	8
DAK075	7,5	41	79	8
DAK076	7,6	41	79	8
DAK077	7,7	41	79	8
DAK078	7,8	41	79	8
DAK079	7,9	41	79	8
DAK080	8,0	41	79	8

DAK-tyypin kovametalliterä

2-leikkuinen erikoispinnoitettu terä 30 ° kulmalla.

Kärkikulma 140 °

Raekoko 0,4 µm.

Soveltuu teräksille kovuuteen 52 HRC asti

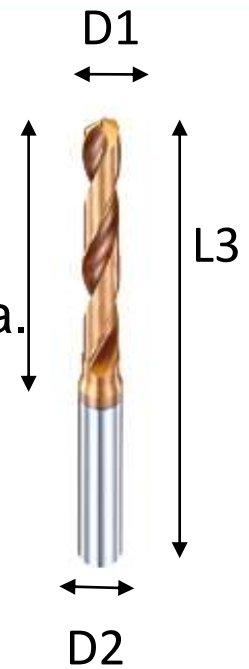

Tyyppi	Halkaisija/ D1	Leikkuu- pituus/L1	Kok.pituus/ L3	Kara/ D2	HINTA
DAK081	8,1	47	89	10	
DAK082	8,2	47	89	10	
DAK083	8,3	47	89	10	
DAK084	8,4	47	89	10	
DAK085	8,5	47	89	10	
DAK086	8,6	47	89	10	
DAK087	8,7	47	89	10	
DAK088	8,8	47	89	10	
DAK089	8,9	47	89	10	
DAK090	9,0	47	89	10	
DAK091	9,1	47	89	10	
DAK092	9,2	47	89	10	
DAK093	9,3	47	89	10	
DAK094	9,4	47	89	10	
DAK095	9,5	47	89	10	
DAK096	9,6	47	89	10	
DAK097	9,7	47	89	10	
DAK098	9,8	47	89	10	
DAK099	9,9	47	89	10	
DAK100	10,0	47	89	10	
DAK101	10,1	55	102	12	
DAK102	10,2	55	102	12	
DAK103	10,3	55	102	12	
DAK104	10,4	55	102	12	
DAK105	10,5	55	102	12	
DAK106	10,6	55	102	12	
DAK107	10,7	55	102	12	
DAK108	10,8	55	102	12	
DAK109	10,9	55	102	12	
DAK110	11,0	55	102	12	
DAK111	11,1	55	102	12	
DAK112	11,2	55	102	12	
DAK113	11,3	55	102	12	

Tyyppi	Halkaisija/ D1	Leikkuu- pituus/L1	Kok.pituus/ L3	Kara/ D2	HINTA
DAK114	11,4	55	102	12	
DAK115	11,5	55	102	12	
DAK116	11,6	55	102	12	
DAK117	11,7	55	102	12	
DAK118	11,8	55	102	12	
DAK119	11,9	55	102	12	
DAK120	12,0	55	102	12	
DAK123	12,3	60	107	14	
DAK125	12,5	60	107	14	
DAK128	12,8	60	107	14	
DAK130	13,0	60	107	14	
DAK135	13,5	60	107	14	
DAK138	13,8	60	107	14	
DAK140	14,0	60	107	14	
DAK145	14,5	65	115	16	
DAK148	14,8	65	115	16	
DAK150	15,0	65	115	16	
DAK155	15,5	65	115	16	
DAK158	15,8	65	115	16	
DAK160	16,0	65	115	16	
DAK165	16,5	73	123	18	
DAK168	16,8	73	123	18	
DAK170	17,0	73	123	18	
DAK175	17,5	73	123	18	
DAK178	17,8	73	123	18	
DAK180	18,0	73	123	18	
DAK185	18,5	79	131	20	
DAK190	19,0	79	131	20	
DAK195	19,5	79	131	20	
DAK198	19,8	79	131	20	
DAK200	20,0	79	131	20	

DBK-tyyppin kovametalliterä

2-leikkuinen erikoispinnoitettu terä 30 °
kulmalla.

Kärkikulma 140 °

Raekoko 0,4 µm.

Soveltuu teräksille kovuuteen 52 HRC
asti

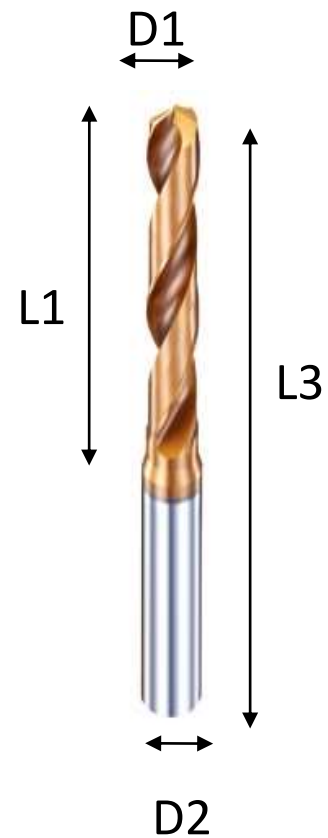

Tyyppi	Halkaisija/ D1	Leikkuu- pituus/L1	Kok.pituus/ L3	Kara/ D2	HINTA
DBK030	3,0	28	66	6	
DBK031	3,1	28	66	6	
DBK032	3,2	28	66	6	
DBK033	3,3	28	66	6	
DBK034	3,4	28	66	6	
DBK035	3,5	28	66	6	
DBK036	3,6	28	66	6	
DBK037	3,7	28	66	6	
DBK038	3,8	36	74	6	
DBK039	3,9	36	74	6	
DBK040	4,0	36	74	6	
DBK041	4,1	36	74	6	
DBK042	4,2	36	74	6	
DBK043	4,3	36	74	6	
DBK044	4,4	36	74	6	
DBK045	4,5	36	74	6	
DBK046	4,6	36	74	6	
DBK047	4,7	36	74	6	
DBK048	4,8	44	82	6	
DBK049	4,9	44	82	6	
DBK050	5,0	44	82	6	
DBK051	5,1	44	82	6	
DBK052	5,2	44	82	6	
DBK053	5,3	44	82	6	
DBK054	5,4	44	82	6	

Tyyppi	Halkaisija/ D1	Leikkuu- pituus/L1	Kok.pituus/ L3	Kara/ D2	HINTA
DBK055	5,5	44	82	6	
DBK056	5,6	44	82	6	
DBK057	5,7	44	82	6	
DBK058	5,8	44	82	6	
DBK059	5,9	44	82	6	
DBK060	6,0	44	82	6	
DBK061	6,1	53	91	8	
DBK062	6,2	53	91	8	
DBK063	6,3	53	91	8	
DBK064	6,4	53	91	8	
DBK065	6,5	53	91	8	
DBK066	6,6	53	91	8	
DBK067	6,7	53	91	8	
DBK068	6,8	53	91	8	
DBK069	6,9	53	91	8	
DBK070	7,0	53	91	8	
DBK071	7,1	53	91	8	
DBK072	7,2	53	91	8	
DBK073	7,3	53	91	8	
DBK074	7,4	53	91	8	
DBK075	7,5	53	91	8	
DBK076	7,6	53	91	8	
DBK077	7,7	53	91	8	
DBK078	7,8	53	91	8	
DBK079	7,9	53	91	8	
DBK080	8,0	53	91	8	

DBK-tyyppin kovametalliterä

2-leikkuinen erikoispinnoitettu terä 30 ° kulmalla.

Kärkikulma 140 °

Raekoko 0,4 µm.

Soveltuu teräksille kovuuteen 52 HRC asti

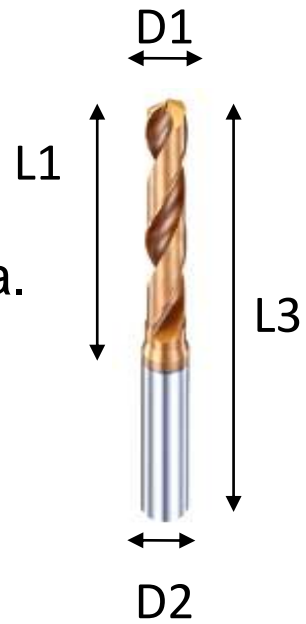

Tyyppi	Halkaisija/ D1	Leikkuu- pituus/L1	Kok.pituus/ L3	Kara/ D2	HINTA
DBK081	8,1	61	103	10	
DBK082	8,2	61	103	10	
DBK083	8,3	61	103	10	
DBK084	8,4	61	103	10	
DBK085	8,5	61	103	10	
DBK086	8,6	61	103	10	
DBK087	8,7	61	103	10	
DBK088	8,8	61	103	10	
DBK089	8,9	61	103	10	
DBK090	9,0	61	103	10	
DBK091	9,1	61	103	10	
DBK092	9,2	61	103	10	
DBK093	9,3	61	103	10	
DBK094	9,4	61	103	10	
DBK095	9,5	61	103	10	
DBK096	9,6	61	103	10	
DBK097	9,7	61	103	10	
DBK098	9,8	61	103	10	
DBK099	9,9	61	103	10	
DBK100	10,0	61	103	10	
DBK101	10,1	71	118	12	
DBK102	10,2	71	118	12	
DBK103	10,3	71	118	12	
DBK104	10,4	71	118	12	
DBK105	10,5	71	118	12	
DBK106	10,6	71	118	12	
DBK107	10,7	71	118	12	
DBK108	10,8	71	118	12	
DBK109	10,9	71	118	12	
DBK110	11,0	71	118	12	
DBK111	11,1	71	118	12	
DBK112	11,2	71	118	12	

Tyyppi	Halkaisija/ D1	Leikkuu- pituus/L1	Kok.pituus/ L3	Kara/ D2	HINTA
DBK113	11,3	71	118	12	
DBK114	11,4	71	118	12	
DBK115	11,5	71	118	12	
DBK116	11,6	71	118	12	
DBK117	11,7	71	118	12	
DBK118	11,8	71	118	12	
DBK119	11,9	71	118	12	
DBK120	12,0	71	118	12	
DBK123	12,3	77	124	14	
DBK125	12,5	77	124	14	
DBK128	12,8	77	124	14	
DBK130	13,0	77	124	14	
DBK135	13,5	77	124	14	
DBK138	13,8	77	124	14	
DBK140	14,0	77	124	14	
DBK145	14,5	83	133	16	
DBK148	14,8	83	133	16	
DBK150	15,0	83	133	16	
DBK155	15,5	83	133	16	
DBK158	15,8	83	133	16	
DBK160	16,0	83	133	16	
DBK165	16,5	93	143	18	
DBK168	16,8	93	143	18	
DBK170	17,0	93	143	18	
DBK175	17,5	93	143	18	
DBK178	17,8	93	143	18	
DBK180	18,0	93	143	18	
DBK185	18,5	101	153	20	
DBK190	19,0	101	153	20	
DBK195	19,5	101	153	20	
DBK198	19,8	101	153	20	
DBK200	20,0	101	153	20	

DAO-tyypin kovametalliterä

2-leikkuinen erikoispinnoitettu terä
30 ° kulmalla.

Kärkikulma 140 °

Raekoko 0,4 µm.

Soveltuu teräksille kovuuteen 52
HRC asti

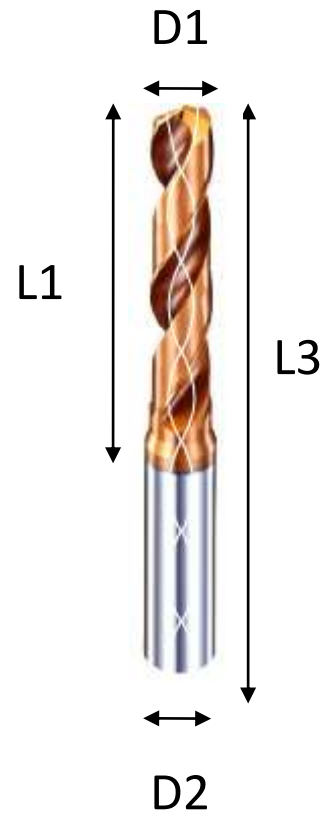

Tyyppi	Halkaisija/ D1	Leikkuu- pituus/L1	Kok.pituus/ L3	Kara/ D2	HINTA
DAO030	3,0	20	62	6	
DAO031	3,1	20	62	6	
DAO032	3,2	20	62	6	
DAO033	3,3	20	62	6	
DAO034	3,4	20	62	6	
DAO035	3,5	20	62	6	
DAO036	3,6	20	62	6	
DAO037	3,7	20	62	6	
DAO038	3,8	24	66	6	
DAO039	3,9	24	66	6	
DAO040	4,0	24	66	6	
DAO041	4,1	24	66	6	
DAO042	4,2	24	66	6	
DAO043	4,3	24	66	6	
DAO044	4,4	24	66	6	
DAO045	4,5	24	66	6	
DAO046	4,6	24	66	6	
DAO047	4,7	24	66	6	
DAO048	4,8	28	66	6	
DAO049	4,9	28	66	6	
DAO050	5,0	28	66	6	
DAO051	5,1	28	66	6	
DAO052	5,2	28	66	6	
DAO053	5,3	28	66	6	
DAO054	5,4	28	66	6	

Tyyppi	Halkaisija/ D1	Leikkuu- pituus/L1	Kok.pituus/ L3	Kara/ D2	HINTA
DAO055	5,5	28	66	6	
DAO056	5,6	28	66	6	
DAO057	5,7	28	66	6	
DAO058	5,8	28	66	6	
DAO059	5,9	28	66	6	
DAO060	6,0	28	66	6	
DAO061	6,1	34	79	8	
DAO062	6,2	34	79	8	
DAO063	6,3	34	79	8	
DAO064	6,4	34	79	8	
DAO065	6,5	34	79	8	
DAO066	6,6	34	79	8	
DAO067	6,7	34	79	8	
DAO068	6,8	34	79	8	
DAO069	6,9	34	79	8	
DAO070	7,0	34	79	8	
DAO071	7,1	41	79	8	
DAO072	7,2	41	79	8	
DAO073	7,3	41	79	8	
DAO074	7,4	41	79	8	
DAO075	7,5	41	79	8	
DAO076	7,6	41	79	8	
DAO077	7,7	41	79	8	
DAO078	7,8	41	79	8	
DAO079	7,9	41	79	8	
DAO080	8,0	41	79	8	

DAO-tyypin kovametalliterä

2-leikkuinen erikoispinnoitettu terä

30 ° kulmalla.

Kärkikulma 140 °

Raekoko 0,4 µm.

Soveltuu teräksille kovuuteen 52

HRC asti

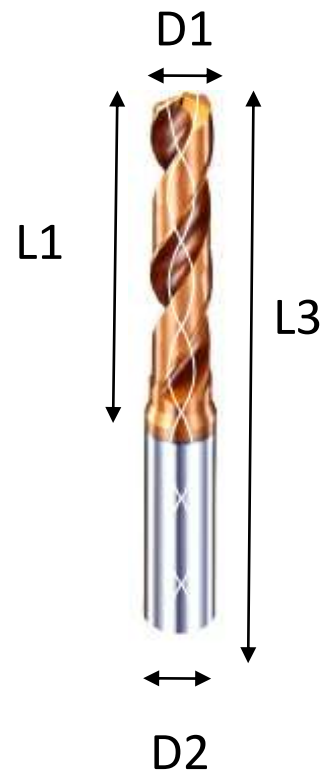

Tyyppi	Halkaisija/ D1	Leikkuu- pituus/L1	Kok.pituus/ L3	Kara/ D2
DAO081	8,1	47	89	10
DAO082	8,2	47	89	10
DAO083	8,3	47	89	10
DAO084	8,4	47	89	10
DAO085	8,5	47	89	10
DAO086	8,6	47	89	10
DAO087	8,7	47	89	10
DAO088	8,8	47	89	10
DAO089	8,9	47	89	10
DAO090	9,0	47	89	10
DAO091	9,1	47	89	10
DAO092	9,2	47	89	10
DAO093	9,3	47	89	10
DAO094	9,4	47	89	10
DAO095	9,5	47	89	10
DAO096	9,6	47	89	10
DAO097	9,7	47	89	10
DAO098	9,8	47	89	10
DAO099	9,9	47	89	10
DAO100	10,0	47	89	10
DAO101	10,1	55	102	12
DAO102	10,2	55	102	12
DAO103	10,3	55	102	12
DAO104	10,4	55	102	12
DAO105	10,5	55	102	12
DAO106	10,6	55	102	12
DAO107	10,7	55	102	12
DAO108	10,8	55	102	12

Tyyppi	Halkaisija/ D1	Leikkuu- pituus/L1	Kok.pituus/ L3	Kara/ D2
DAO109	10,9	55	102	12
DAO110	11,0	55	102	12
DAO111	11,1	55	102	12
DAO112	11,2	55	102	12
DAO113	11,3	55	102	12
DAO114	11,4	55	102	12
DAO115	11,5	55	102	12
DAO116	11,6	55	102	12
DAO117	11,7	55	102	12
DAO118	11,8	55	102	12
DAO119	11,9	55	102	12
DAO120	12,0	55	102	12
DAO125	12,5	60	107	14
DAO130	13,0	60	107	14
DAO135	13,5	60	107	14
DAO140	14,0	60	107	14
DAO145	14,5	65	115	16
DAO150	15,0	65	115	16
DAO155	15,5	65	115	16
DAO160	16,0	65	115	16
DAO165	16,5	73	123	18
DAO170	17,0	73	123	18
DAO175	17,5	73	123	18
DAO180	18,0	73	123	18
DAO185	18,5	79	131	20
DAO190	19,0	79	131	20
DAO195	19,5	79	131	20
DAO200	20,0	79	131	20

DBO-tyypin kovametalliterä

2-leikkuinen erikoispinnoitettu terä

30 ° kulmalla.

Kärkikulma 140 °

Raekoko 0,4 µm.

Soveltuu teräksille kovuuteen 52

HRC asti

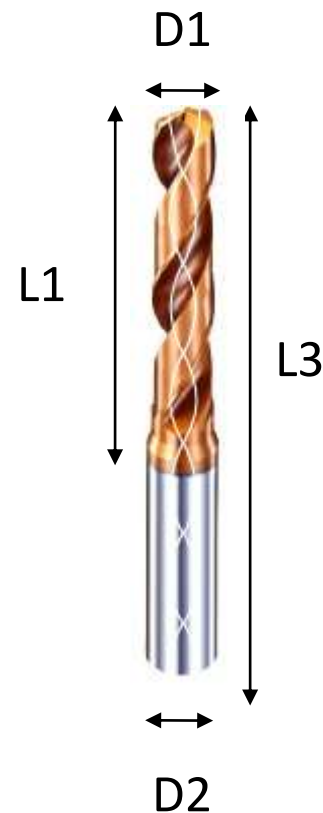

Tyyppi	Halkaisija/ D1	Leikkuu- pituus/L1	Kok.pituus/ L3	Kara/ D2
DBO030	3,0	28	66	6
DBO031	3,1	28	66	6
DBO032	3,2	28	66	6
DBO033	3,3	28	66	6
DBO034	3,4	28	66	6
DBO035	3,5	28	66	6
DBO036	3,6	28	66	6
DBO037	3,7	28	66	6
DBO038	3,8	36	74	6
DBO039	3,9	36	74	6
DBO040	4,0	36	74	6
DBO041	4,1	36	74	6
DBO042	4,2	36	74	6
DBO043	4,3	36	74	6
DBO044	4,4	36	74	6
DBO045	4,5	36	74	6
DBO046	4,6	36	74	6
DBO047	4,7	36	74	6
DBO048	4,8	44	82	6
DBO049	4,9	44	82	6
DBO050	5,0	44	82	6
DBO051	5,1	44	82	6
DBO052	5,2	44	82	6
DBO053	5,3	44	82	6
DBO054	5,4	44	82	6

Tyyppi	Halkaisija/ D1	Leikkuu- pituus/L1	Kok.pituus/ L3	Kara/ D2
DBO055	5,5	44	82	6
DBO056	5,6	44	82	6
DBO057	5,7	44	82	6
DBO058	5,8	44	82	6
DBO059	5,9	44	82	6
DBO060	6,0	44	82	6
DBO061	6,1	53	91	8
DBO062	6,2	53	91	8
DBO063	6,3	53	91	8
DBO064	6,4	53	91	8
DBO065	6,5	53	91	8
DBO066	6,6	53	91	8
DBO067	6,7	53	91	8
DBO068	6,8	53	91	8
DBO069	6,9	53	91	8
DBO070	7,0	53	91	8
DBO071	7,1	53	91	8
DBO072	7,2	53	91	8
DBO073	7,3	53	91	8
DBO074	7,4	53	91	8
DBO075	7,5	53	91	8
DBO076	7,6	53	91	8
DBO077	7,7	53	91	8
DBO078	7,8	53	91	8
DBO079	7,9	53	91	8
DBO080	8,0	53	91	8

DBO-tyypin kovametalliterä

2-leikkuinen erikoispinnoitettu terä

30 ° kulmalla.

Kärkikulma 140 °

Raekoko 0,4 µm.

Soveltuu teräksille kovuuteen 52

HRC asti

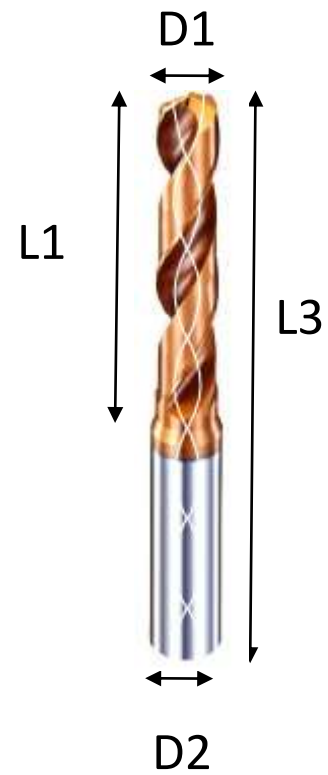

Tyyppi	Halkaisija/ D1	Leikkuu- pituus/L1	Kok.pituus/ L3	Kara/ D2
DBO081	8,1	61	103	10
DBO082	8,2	61	103	10
DBO083	8,3	61	103	10
DBO084	8,4	61	103	10
DBO085	8,5	61	103	10
DBO086	8,6	61	103	10
DBO087	8,7	61	103	10
DBO088	8,8	61	103	10
DBO089	8,9	61	103	10
DBO090	9,0	61	103	10
DBO091	9,1	61	103	10
DBO092	9,2	61	103	10
DBO093	9,3	61	103	10
DBO094	9,4	61	103	10
DBO095	9,5	61	103	10
DBO096	9,6	61	103	10
DBO097	9,7	61	103	10
DBO098	9,8	61	103	10
DBO099	9,9	61	103	10
DBO100	10,0	61	103	10
DBO101	10,1	71	118	12
DBO102	10,2	71	118	12
DBO103	10,3	71	118	12
DBO104	10,4	71	118	12
DBO105	10,5	71	118	12
DBO106	10,6	71	118	12
DBO107	10,7	71	118	12
DBO108	10,8	71	118	12

Tyyppi	Halkaisija/ D1	Leikkuu- pituus/L1	Kok.pituus/ L3	Kara/ D2
DBO109	10,9	71	118	12
DBO110	11,0	71	118	12
DBO111	11,1	71	118	12
DBO112	11,2	71	118	12
DBO113	11,3	71	118	12
DBO114	11,4	71	118	12
DBO115	11,5	71	118	12
DBO116	11,6	71	118	12
DBO117	11,7	71	118	12
DBO118	11,8	71	118	12
DBO119	11,9	71	118	12
DBO120	12,0	71	118	12
DBO125	12,5	77	124	14
DBO130	13,0	77	124	14
DBO135	13,5	77	124	14
DBO140	14,0	77	124	14
DBO145	14,5	83	133	16
DBO150	15,0	83	133	16
DBO155	15,5	83	133	16
DBO160	16,0	83	133	16
DBO165	16,5	93	143	18
DBO170	17,0	93	143	18
DBO175	17,5	93	143	18
DBO180	18,0	93	143	18
DBO185	18,5	101	153	20
DBO190	19,0	101	153	20
DBO195	19,5	101	153	20
DBO200	20,0	101	153	20

DCO-tyypin kovametalliterä

2-leikkuinen erikoispinnoitettu terä
30 ° kulmalla.

Kärkikulma 140 °

Raekoko 0,4 µm.

Soveltuu teräksille kovuuteen 52
HRC asti

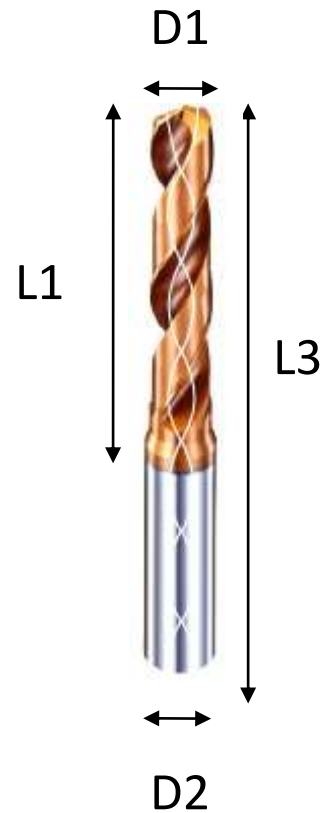

Tyyppi	Halkaisija/ D1	Leikkuu- pituus/L1	Kok.pituus/ L3	Kara/ D2
DCO040	4,0	43	81	6
DCO041	4,1	43	81	6
DCO042	4,2	43	81	6
DCO043	4,3	43	81	6
DCO044	4,4	43	81	6
DCO045	4,5	43	81	6
DCO046	4,6	43	81	6
DCO047	4,7	43	81	6
DCO048	4,8	57	95	6
DCO049	4,9	57	95	6
DCO050	5,0	57	95	6
DCO051	5,1	57	95	6
DCO052	5,2	57	95	6
DCO053	5,3	57	95	6
DCO054	5,4	57	95	6
DCO055	5,5	57	95	6
DCO056	5,6	57	95	6
DCO057	5,7	57	95	6
DCO058	5,8	57	95	6
DCO059	5,9	57	95	6
DCO060	6,0	57	95	6
DCO061	6,1	76	114	8
DCO062	6,2	76	114	8
DCO063	6,3	76	114	8
DCO064	6,4	76	114	8

Tyyppi	Halkaisija/ D1	Leikkuu- pituus/L1	Kok.pituus/ L3	Kara/ D2
DCO065	6,5	76	114	8
DCO066	6,6	76	114	8
DCO067	6,7	76	114	8
DCO068	6,8	76	114	8
DCO069	6,9	76	114	8
DCO070	7,0	76	114	8
DCO071	7,1	76	114	8
DCO072	7,2	76	114	8
DCO073	7,3	76	114	8
DCO074	7,4	76	114	8
DCO075	7,5	76	114	8
DCO076	7,6	76	114	8
DCO077	7,7	76	114	8
DCO078	7,8	76	114	8
DCO079	7,9	76	114	8
DCO080	8,0	76	114	8
DCO081	8,1	95	142	10
DCO082	8,2	95	142	10
DCO083	8,3	95	142	10
DCO084	8,4	95	142	10
DCO085	8,5	95	142	10
DCO086	8,6	95	142	10
DCO087	8,7	95	142	10
DCO088	8,8	95	142	10
DCO089	8,9	95	142	10
DCO090	9,0	95	142	10

DCO-tyypin kovametalliterä

2-leikkuinen erikoispinnoitettu terä
30 ° kulmalla.

Kärkikulma 140 °

Raekoko 0,4 µm.

Soveltuu teräksille kovuuteen 52

HRC asti

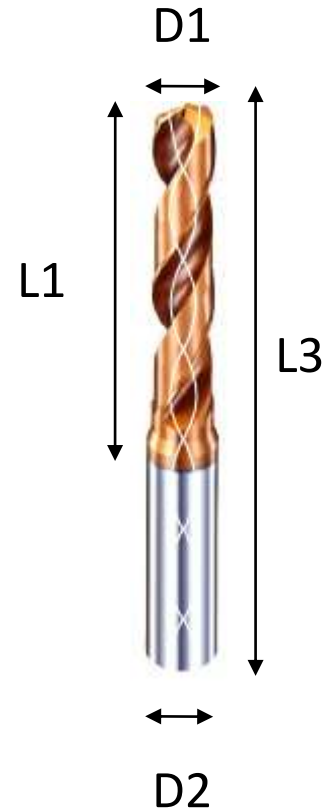

Tyyppi	Halkaisija/ D1	Leikkuu- pituus/L1	Kok.pituus/ L3	Kara/ D2
DCO091	9,1	61	103	10
DCO092	9,2	61	103	10
DCO093	9,3	61	103	10
DCO094	9,4	61	103	10
DCO095	9,5	61	103	10
DCO096	9,6	61	103	10
DCO097	9,7	61	103	10
DCO098	9,8	61	103	10
DCO099	9,9	61	103	10
DCO100	10,0	61	103	10
DCO101	10,1	71	118	12
DCO102	10,2	71	118	12
DCO103	10,3	71	118	12
DCO104	10,4	71	118	12
DCO105	10,5	71	118	12
DCO106	10,6	71	118	12
DCO107	10,7	71	118	12
DCO108	10,8	71	118	12

Tyyppi	Halkaisija/ D1	Leikkuu- pituus/L1	Kok.pituus/ L3	Kara/ D2
DCO109	10,9	71	118	12
DCO110	11,0	71	118	12
DCO111	11,1	71	118	12
DCO112	11,2	71	118	12
DCO113	11,3	71	118	12
DCO114	11,4	71	118	12
DCO115	11,5	71	118	12
DCO116	11,6	71	118	12
DCO117	11,7	71	118	12
DCO118	11,8	71	118	12
DCO119	11,9	71	118	12
DCO120	12,0	71	118	12

HW-typin kierre terä

Nelileikkuinen

TiSiN-pinnoite

Teräksille kovuuteen HRC60 asti

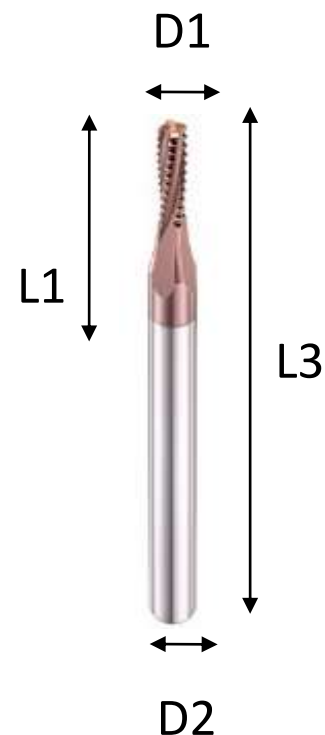

Koodi	DIA/ D2	Leikkuu- pituus L1	Pituus/ L3	Kara/ D2	Leikuu/ kpl	Nousu	Kierre	
HW0230505	2.3	5.26	40	6	4	0.5	M3	
HW0230705	2.3	7.26	40	6	4	0.5	M3	
HW0300707	3.0	7.32	40	6	4	0.7	M4	
HW0301007	3.0	10.12	40	6	4	0.7	M4	
HW0380908	3.8	9.15	50	6	4	0.8	M5	
HW0381208	3.8	12.35	50	6	4	0.8	M5	
HW0451110	4.5	11.41	60	6	4	1.0	M6	
HW0451510	4.5	15.41	60	6	4	1.0	M6	
HW06014125	6.0	14.24	60	6	4	1.25	M8	
HW06019125	6.0	19.24	60	6	4	1.25	M8	

TW-tyyppin kierre terä

3 – 5 -leikkuinen

G10-pinnoite

Teräksille kovuuteen HRC60 asti

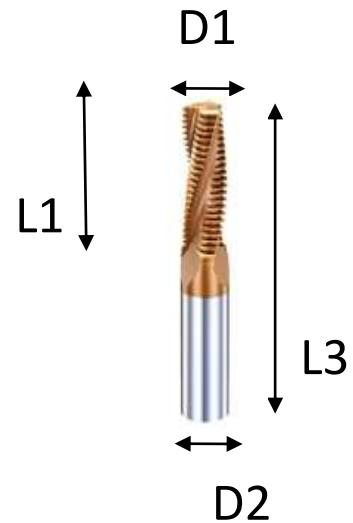

Koodi	D1A/ D2	Leikkuu- pituus L1	Pituus/ L3	Kara/ D2	Leikuu/ kpl	Nousu	Kierre	
TW02305M3050	2.3	5	40	6	3	0.5	M3	
TW02307M3050	2.3	7	40	6	3	0.5	M3	
TW03007M4070	3.0	7	40	6	3	0.7	M4	
TW03010M4070	3.0	10	40	6	3	0.7	M4	
TW03809M5080	3.8	9	50	6	3	0.8	M5	
TW03812M5080	3.8	12	50	6	3	0.8	M5	
TW04511M6100	4.5	11	60	6	3	1.0	M6	
TW04515M6100	4.5	15	60	6	3	1.0	M6	
TW06014M8125	6.0	14	60	8	3	1.25	M8	
TW06019M8125	6.0	19	60	8	3	1.25	M8	
TW07517M10150	7.5	17	60	8	3	1.5	M10	
TW07525M10150	7.5	25	75	8	3	1.5	M10	
TW08020M12175	8.0	20	60	8	3	1.75	M12	
TW08029M12175	8.0	29	75	8	3	1.75	M12	
TW09020M12175	9.0	20	75	10	4	1.75	M12	
TW09029M12175	9.0	29	75	10	4	1.75	M12	
TW10027M14200	10.0	27	75	10	4	2.0	M14	
TW10039M14200	10.0	39	100	10	4	2.0	M14	
TW12027M16200	12.0	27	80	12	4	2.0	M16	
TW12031M18250	12.0	31	100	12	4	2.5	M18	
TW12039M16200	12.0	39	100	12	4	2.0	M16	
TW12045M16200	12.0	45	100	12	4	2.5	M18	
TW14034M20250	14.0	34	100	14	4	2.5	M20	
TW14049M20250	14.0	49	100	14	4	2.5	M20	
TW16041M24300	16.0	41	100	16	5	3.0	M24	
TW16059M24300	16.0	59	120	16	5	3.0	M24	

X-WDEX-tyyppin vaihtoterä- adapteri

Tyyppi	Halkaisija/ D1	Kok.pituus/ L1	Kierre/ M
X-WDEX-080060	8	60	M5
X-WDEX-080075	8	75	M5
X-WDEX-080100	8	100	M5
X-WDEX-100060	10	60	M7
X-WDEX-100075	10	75	M7
X-WDEX-100100	10	100	M7
X-WDEX-100150	10	150	M7
X-WDEX-120060	12	60	M8
X-WDEX-120080	12	80	M8
X-WDEX-120100	12	100	M8
X-WDEX-120150	12	150	M8
X-WDEX-160060	16	60	M10
X-WDEX-160080	16	80	M10
X-WDEX-160100	16	100	M10
X-WDEX-160150	16	150	M10
X-WDEX-160200	16	200	M10
X-WDEX-200060	20	60	M12
X-WDEX-200080	20	80	M12
X-WDEX-200100	20	100	M12
X-WDEX-200150	20	150	M12
X-WDEX-200200	20	200	M12
X-WDEX-200250	20	250	M12
X-WDEX-200300	20	300	M12
X-WDEX-250100	25	100	M16
X-WDEX-250150	25	150	M16
X-WDEX-250200	25	200	M16
X-WDEX-250250	25	250	M16
X-WDEX-250300	25	300	M16
X-WDEX-320100	32	100	M21
X-WDEX-320150	32	150	M21
X-WDEX-320200	32	200	M21
X-WDEX-320250	32	250	M21
X-WDEX-320300	32	300	M21

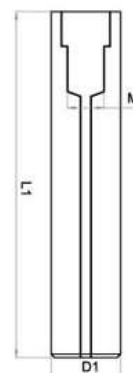

TW-tyypin kierreterä



Vaihto kärki

Nelileikkuinen

G12-pinnoite

Teräksille kovuuteen HRC55 asti



Tyyppi	Dia	Leikkuu pituus	Nousu	Kierteiden määrä	Karkea kierre	Hieno kierre	Suosittelut adapteri
X-TW101210	10.0	12.0	1.0	12		≥M14	X-WDEX080-
X-TW121510	12.0	15.0	1.0	15		≥M15	X-WDEX100-
X-TW161810	16.0	18.0	1.0	18		≥M20	X-WDEX120-
X-TW202110	20.0	21.0	1.0	21		≥M24	X-WDEX160-
X-TW111215	11.0	12.0	1.5	8		≥M15	X-WDEX080-
X-TW131515	13.0	15.0	1.5	10		≥M17	X-WDEX100-
X-TW161815	16.0	18.0	1.5	12		≥M20	X-WDEX120-
X-TW202115	20.0	21.0	1.5	14		≥M24	X-WDEX160-
X-TW252415	25.0	24.0	1.5	16		≥M30	X-WDEX200-
X-TW111220	11.0	12.0	2.0	6	M16	≥M18	X-WDEX080-
X-TW131420	13.0	14.0	2.0	7		≥M18	X-WDEX100-
X-TW161820	16.0	18.0	2.0	9		≥M22	X-WDEX120-
X-TW202220	20.0	22.0	2.0	11		≥M25	X-WDEX160-
X-TW252420	25.0	24.0	2.0	12		≥M30	X-WDEX200-
X-TW131525	13.0	15.0	2.5	6	M18~22		X-WDEX100- TAI X-WHEX-
X-TW161830	16.0	18.0	3.0	6	M24~27	≥M30	X-WDEX120-TAI X-WHEX-
X-TW202130	20.0	21.0	3.0	7		≥M30	X-WDEX160-
X-TW252430	25.0	24.0	3.0	8		≥M33	X-WDEX200-
X-TW202135	20.0	21.0	3.5	6	M30~33		X-WDEX160- TAI X-WHEX160 -
X-TW252440	25.0	24.0	4.0	6	M36~39	≥M42	X-WDEX200-

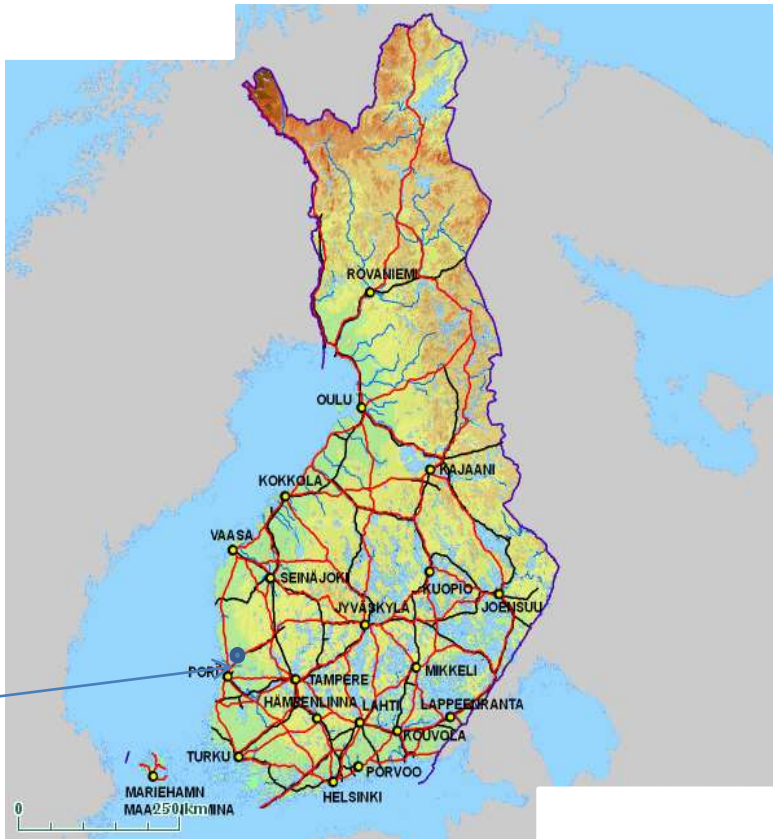

Mouldin Oy
Noormarkku

MOULDin Oy

Museotie 4
29600 Noormarkku
02 6384 999
info@mouldin.fi
www.mouldin.fi